

# LITTLE BLASTER™

Distributed By:



2717 Tobey • Indianapolis, IN 46219  
(317) 545-0665 • FAX (317) 545-0670 • (800) 800-0665  
www.idsblast.com

## LITTLE BLASTER™ OYSTER SHELL WITH 300 CFM RECLAIM

**MANUAL NUMBER: 563**

### TABLE OF CONTENTS

<i>PAGE</i>	<i>FIGURE</i>	
<i>1</i>	<i>-</i>	<i>SET-UP INSTRUCTIONS</i>
<i>2</i>	<i>-</i>	<i>OPERATING INSTRUCTIONS</i>
<i>3</i>	<i>-</i>	<i>GENERAL MAINTENANCE</i>
<i>4</i>	<i>1</i>	<i>STANDARD CABINET PARTS</i>
<i>5</i>	<i>2</i>	<i>AIR CONTROL, SET-UP</i>
<i>6</i>	<i>3</i>	<i>AIR CONTROL, PARTS</i>
<i>7</i>	<i>4</i>	<i>MACHINE LIGHTING, PARTS</i>
<i>8</i>	<i>5</i>	<i>BLAST GUN, PARTS</i>
<i>9</i>	<i>6</i>	<i>RECLAIM, INSTALLATION</i>
<i>10</i>	<i>7</i>	<i>RECLAIM, PARTS</i>
<i>11</i>	<i>8</i>	<i>ELECTRICAL DIAGRAM</i>
<i>12</i>	<i>-</i>	<i>MACHINE WARRANTY</i>
<i>13</i>	<i>-</i>	<i>WARRANTY REGISTRATION FORM</i>

## **WARNING**

**DO NOT USE SAND.** SAND WILL CAUSE SILICA DUST, WHICH IS THE CAUSE OF SILICOSIS DISEASE, A CONDITION OF MASSIVE FIBROSIS OF THE LUNGS. THIS STATEMENT INDICATES POTENTIAL PERSONNEL HAZARD. FAILURE TO COMPLY WITH THESE INSTRUCTIONS MAY RESULT IN PERSONAL INJURY.

WEBSITE CONCERNING SILICOSIS:

<http://www.osha.gov/Silica/IT69D 1.html>

# LITTLE BLASTER™ OYSTER SHELL

## SET-UP INSTRUCTIONS

### MACHINES WITH 300 CFM RECLAIM

**\*\*\* READ BEFORE OPERATING EQUIPMENT \*\*\***

1. Remove shipping protection. Lift the top section, (JUST ENOUGH) to remove the hardware and rear leg supports.
2. Install the rear leg supports and remove the lag bolts from each of the four legs, then remove machine from the pallet.
3. Remove reclaim, and boxes, from machine
4. Install air controls, hoses, foot control regulator, etc.  
**(SEE PAGE 5 - FIGURE 2)**
5. Lift grate and pull gun and hoses into slot provided in front center grate. Lower grate back into place.
6. Remove metal straps from reclaimer.
7. Open bag of hardware, nuts, bolts, clamps, putty tape, etc. **(REFER TO FIGURE 6 - PAGE 9)**
8. Position reclaimer with mounting bracket (#1) so that the inlet hole on bracket is aligned with the inlet hole on reclaim bracket. Secure reclaimer to the machine with bolts provided using four holes punched on the mounting bracket. (Two people are needed to install the reclaimer).
9. Attach media hose (#12), that feeds to bottom of blast gun housing from to media valve (#10).
10. Attach flex hose (#13), to sump adapter (#14), and reclaimer inlet with clamps (#15).
11. Attach filter bag (#17), to reclaimer outlet with hose clamp (#16).
12. Connect to reclaimer motor male plug (#6), to female plug cord from the light box.
13. Connect compressed air supply to fitting provided on left rear leg of the machine. Air piping should be of the same size as the connection point, offering no restriction to flow.  
**(DO NOT USE QUICK-DISCONNECTS)**
14. Connect the factory installed male cord from light box, to a 120-Volt, 60 HZ, 1 Phase power supply. A 20 AMP breaker or fuse should be used.

**MAKE SURE MACHINE IS PROPERLY GROUNDED.**

# LITTLE-BLASTER™ OYSTER SHELL OPERATING INSTRUCTIONS MACHINE WITH RECLAIM

\*\*\* READ BEFORE OPERATING EQUIPMENT \*\*\*

## 1. Preparing parts for Blasting:

All parts to be processed must be free of oil, grease, and moisture. Make sure parts are dry before putting into cabinet for cleaning.

## 2. Air Pressure:

Set air pressure at 80 PSI. Most parts for blasting cleaning cabinet should be blasted at 80 PSI. Designate parts to be processed, start at lower pressure and work up the PSI scale to obtain desired finish.

\*\*\*WARNING\*\*\*

DO NOT CONNECT TO HIGH PRESSURE BOTTLE GAS, RUPTURE AND EXPLOSION CAN OCCUR.

## 3. Gun Angle and Distance:

Direct blast at part with an approximate (45-60) degree angle with ricochet toward the back side of cabinet. Do not hold at 90 degree to part being processed. This will cause the blast media to bounce back into the blast stream and slow blasting action. Also 90-degree angle will cause excessive wear on gun and viewing window. Hold gun approximately 6 inches from part being cleaned.

\*\*\*WARNING\*\*\*

GUN MUST ALWAYS BE POINTED AWAY FROM THE OPERATOR AND TOWARD ITEM BEING PROCESSED. NEVER BLAST WITH ANY OF THE CABINET DOORS OPEN. WHILE LOADING AND UNLOADING, NO ONE SHOULD BE AT THE OPERATOR STATION AT FRONT OF THE BLAST CABINET.

## 4. Media:

Media should be good quality and dry. Damp media will cause the media not to flow and will clog abrasive flow. **NEVER USE SAND.** See **\*\*CAUTION\*\***, below. If you are having a problem selecting media for a specified job, contact your distributor for their recommendations.

**\*\*CAUTION\*\* \*\*CAUTION\*\* DO NOT USE SAND BLASTING SAND. THIS WILL CAUSE SILICA DUST WHICH IS THE CAUSE OF SILICOSIS DISEASE, A CONDITION OF MASSIVE FIBROSIS OF THE LUNGS.**

**LITTLE-BLASTER™ OYSTER SHELL  
MAINTENANCE INSTRUCTIONS  
MACHINE WITH RECLAIM**

**\*\*\* READ BEFORE OPERATING EQUIPMENT \*\*\***

**1. Blasting Gun:**

After 10 - 12 hours of blasting time the air orifice and nozzle should be checked. If the nozzle shows wear, rotate 1/4 turn to prevent uneven wear. If this is not checked, it could result in destruction of nozzle and damage to the gun housing. If wear is detected on the orifice tip, replace.

**2. Caking of Media:**

- A. Media caking is caused by moisture in compressed air supply or oily and greasy parts. If this is not corrected, media will not flow and will clog gun. Check air supply. If water or moisture is present, install a good moisture trap. If oily or greasy parts are being blast treated, you should first degrease and dry parts.
- B. If blast gun should occasionally clog, place thumb over nozzle (hold tight) and push foot valve down 3 to 4 seconds. This will cause the system to back blast through the gun and media hose, and clear the media hose.

**3. Gun Air Pressure Drop:**

Set air regulator at 80 PSI on air gauge. Push foot valve and if gauge reading should drop, check the air supply pipe or hose. A restriction in the supply line such as reducers or quick couplers will cause pressure drop. Also, if the blast cabinet is too far from the air compressor, a pressure drop can occur. We recommend 1/2" - 1" I.D. air supply line. The bigger the better.

**4. Poor Visibility - Excessive Dust:**

- A. Cabinet Air inlet blocked, check for blockage.
- B. Dust collector bag needs emptied.
- C. With motor off, grasp bag and shake.
- D. Media breakdown - replace media and clean dust collector.

**5. Poor Media Flow:**

- A. Wet or damp media caused from moisture or oil in compressed air line.
- B. Use dry air or install a moisture filter.
- C. Replace media and clean media sump and hose.
- D. Media level should be below media screen.
- E. Hole in media hose from wear, replace hose assembly.

**\*\*CAUTION**

**\*\*CAUTION\*\***

**DO NOT OPEN ANY OF THE DOORS  
WHILE MACHINE IS IN OPERATION**

**\*\*CAUTION\*\***

**\*\*CAUTION\*\***

**DO NOT USE SAND BLASTING SAND.  
THIS WILL CAUSE SILICA DUST  
WHICH IS THE CAUSE OF SILICOSIS  
DISEASE, A CONDITION OF MASSIVE  
FIBROSIS OF THE LUNGS.**

# LITTLE-BLASTER™

## OYSTER SHELL PARTS

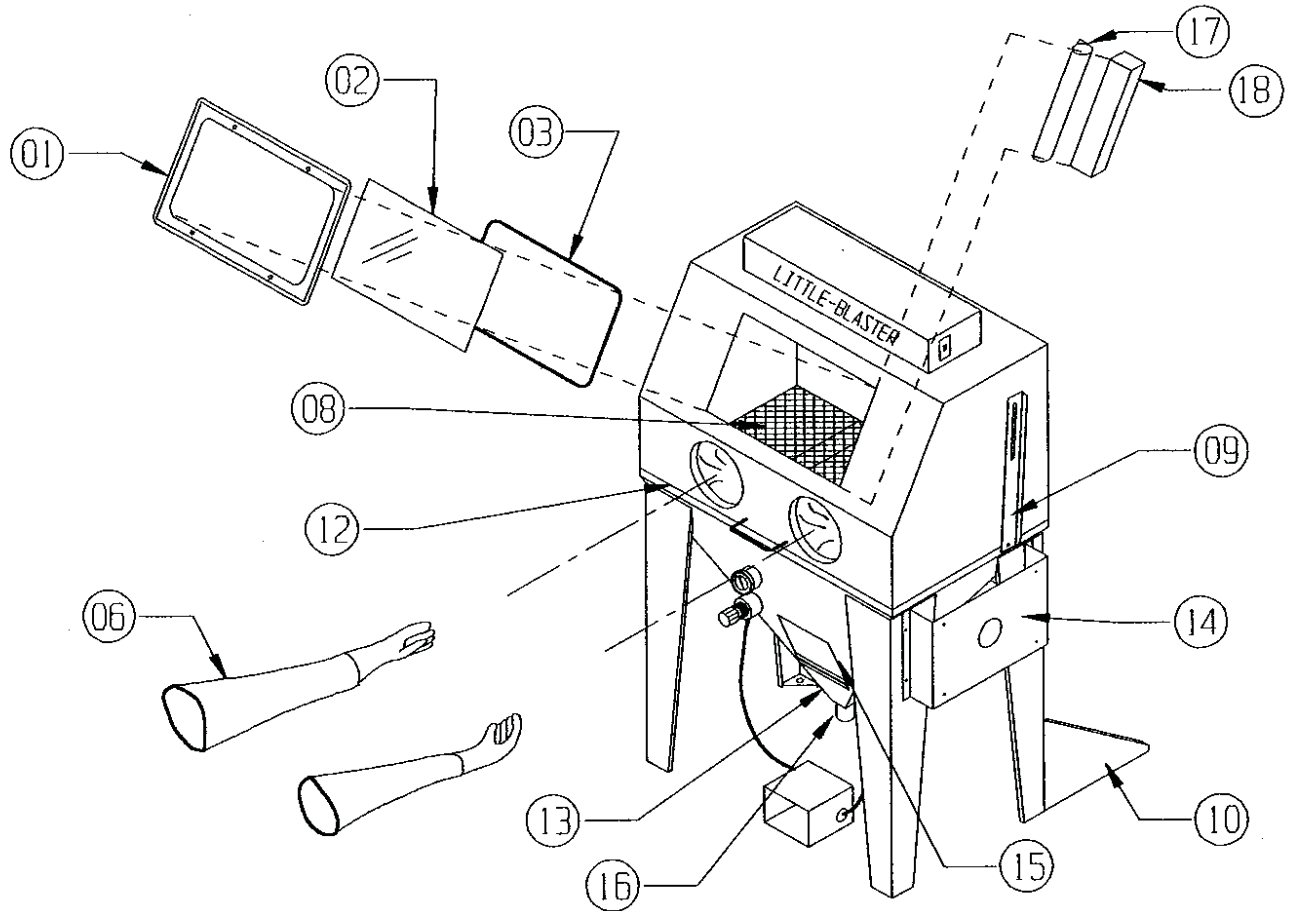

ITEM NO.	PART NO.	DESCRIPTION
1	23-053	WINDOW FRAME
2	23-050	WINDOW, VIEWING
3	24-054-64	WINDOW GASKET
4	-----	-----
5	-----	-----
6A	22-111	GLOVE, SNAP-IN (LEFT ONLY)
6B	22-112	GLOVE, SNAP-IN (RIGHT ONLY)
7	-----	-----
8	10-152-42	GRATE (LB 4224DS)
9	0112-23	TOP SLIDE LATCH
10	0112-25	LEG SUPPORT
11	15-720	DOOR CAM RUBBER GRIP
12	24-054-132	GASKET
13	10-050-42	SUMP SCREEN (LB 4224DS)
14	0112-24	DUST COLLECTOR OR RECLAIMER MOUNT
15	24-055	CLEAN OUT DOOR GASKET
16	20-200	MEDIA VALVE
17	011191	MYLAR GLASS PROTECTOR
18	011190	MYLAR HOLDER

**Figure 1**

# LITTLE-BLASTER™

## SET-UP INSTRUCTIONS

### LITTLE-BLASTER AIR CONTROLS INSTALLATION

\*\*\* READ BEFORE OPERATING EQUIPMENT \*\*\*

1. Remove box from machine with Blast Gun and Air Controls.
2. Connect regulator to bracket with lock ring.
3. Connect inlet air hose to left rear leg of machine.
4. Run air hose through machine sump grommet and connect to gun handle.
5. Connect media hose to pick-up tube.

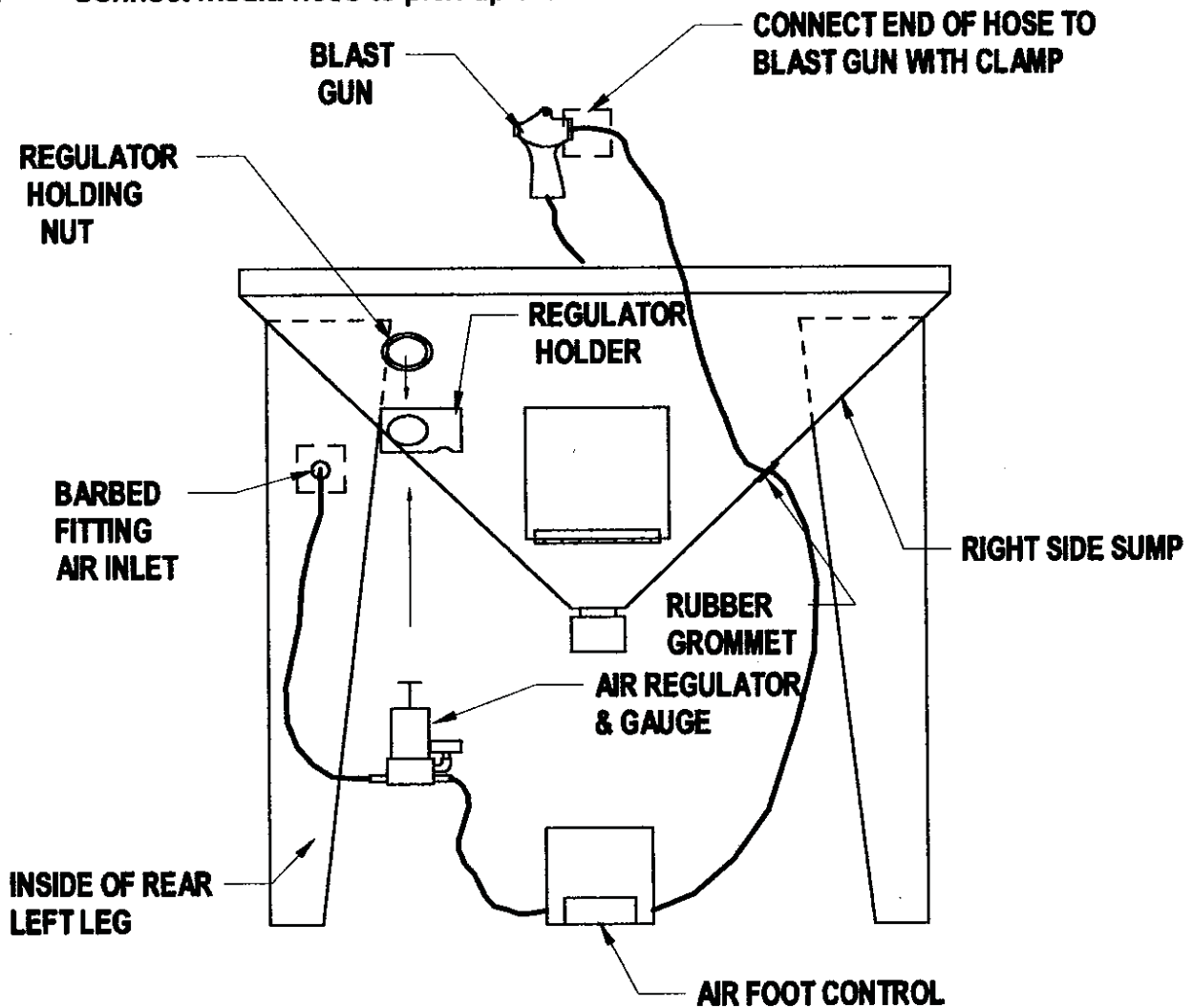
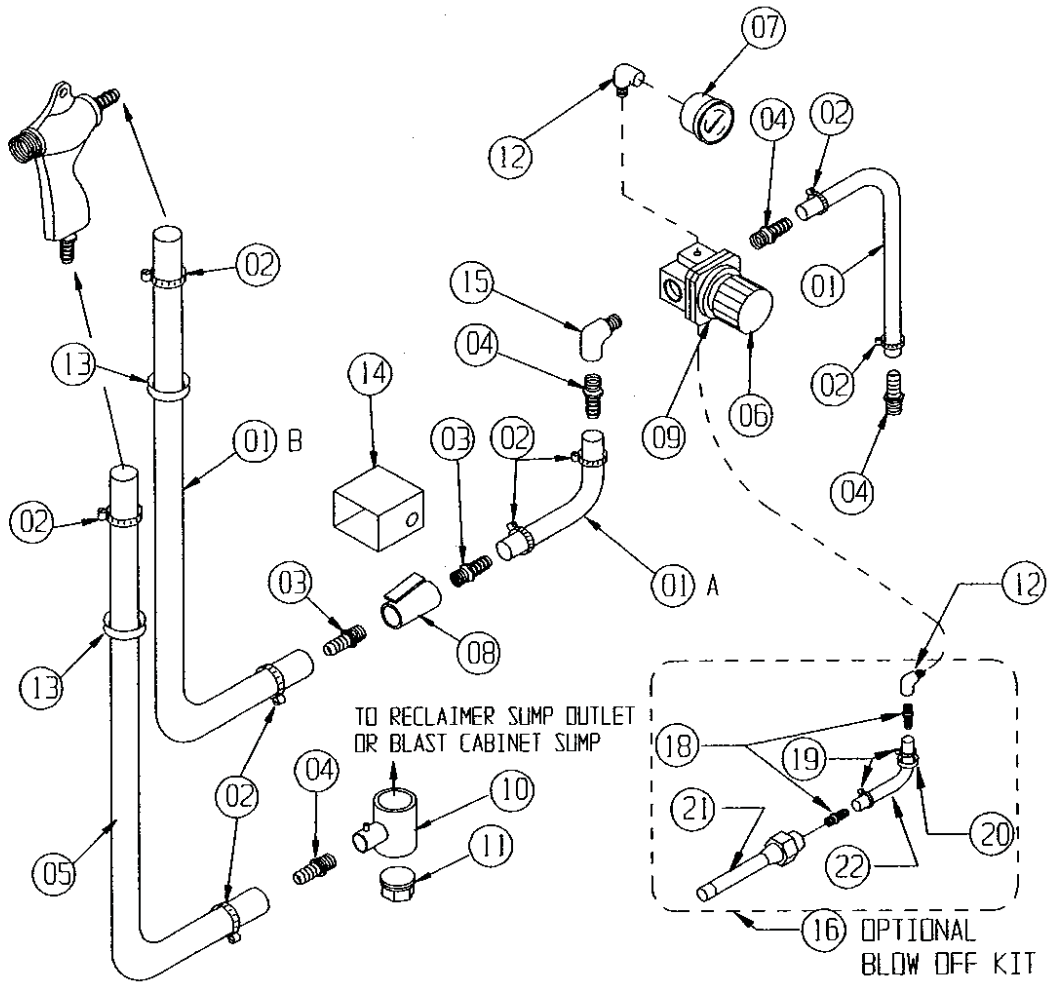

Figure 2

MACHINE AIR CONTROLS



ITEM NO.	PART NO.	DESCRIPTION
1	18-076-2	HOSE, AIRLINE (2 FT.)
1A	18-076-3	HOSE, AIRLINE (3 FT.)
1B	18-076-7	HOSE, AIRLINE (7 FT.)
2	21-032	CLAMP, HOSE
3	14-302	FITTING, 1/2" HOSE x 3/8" MPT
4	14-301	FITTING, 1/2" HOSE x 1/2" MPT
5	18-084-6	HOSE, MEDIA LINE (6 FT.)
6	16-965	REGULATOR, AIR 1/2"
7	16-820	GAUGE, AIR
8	16-835	VALVE, AIR FOOT CONTROL ONLY
9	16-965LR	REGULATOR LOCK RING
10	20-200	MEDIA VALVE
11	20-201	PLUG (MEDIA VALVE)
12	002301	1/4" STREET ELL
13	24-050	GROMMET, HOSE
14	16-836	HOUSING, FOOT CONTROL ONLY (NO VALVE)
15	14-372	1/2" STREET ELL
16	009059	OPTIONAL BLOW OFF KIT
17		-----
18	14-313	FITTING, 1/4 x 1/4 NPT
19	010412	CLAMP, 1/4" AIR HOSE
20	24-052	GROMMET
21	16-822	BLOW OFF NOZZLE
22	000738-6	HOSE, 1/4" AIR x 6' LONG

Figure 3

**LITTLE-BLASTER™**  
**ELECTRICAL DIAGRAM**

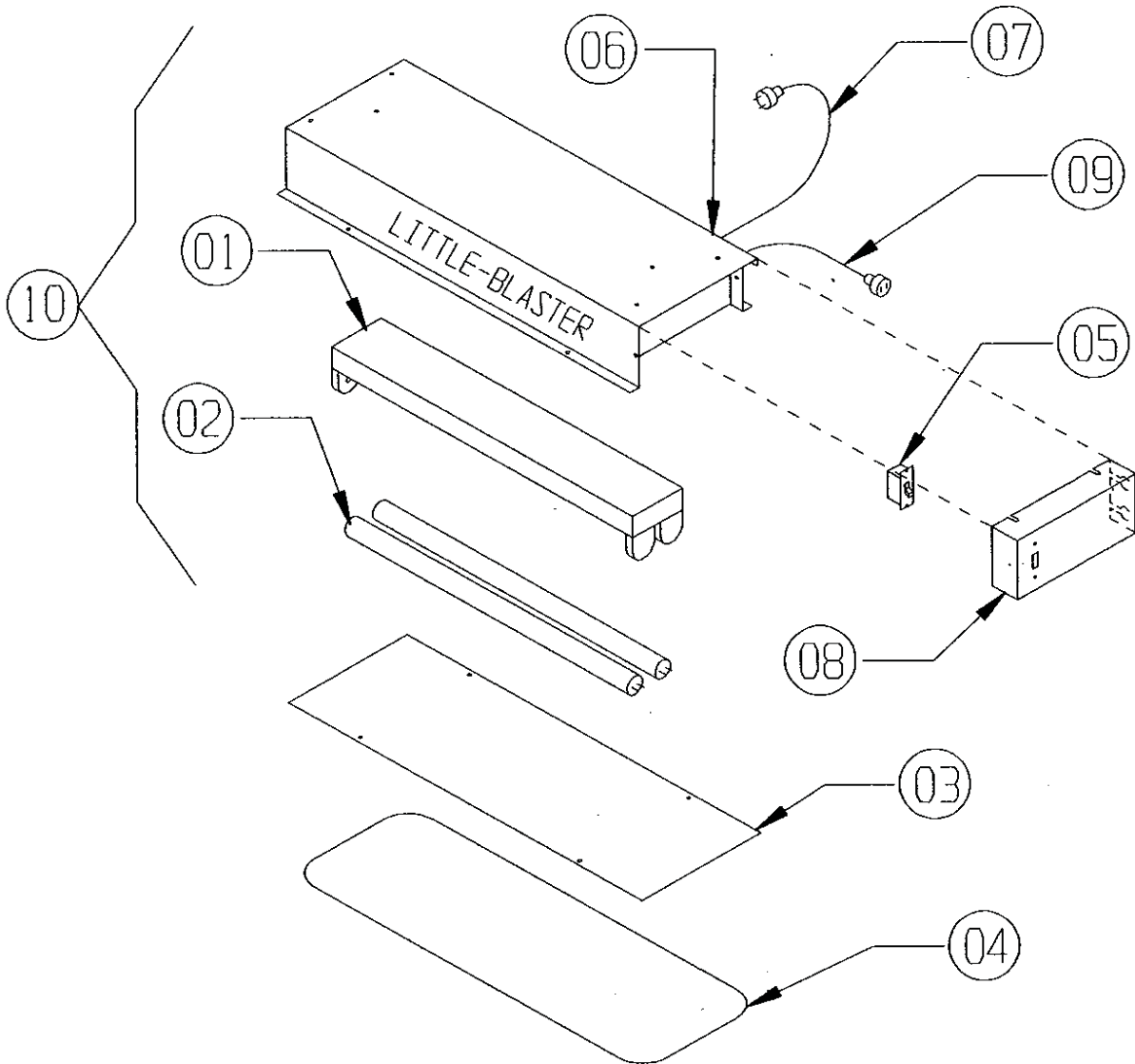

ITEM NO.	PART NO.	DESCRIPTION
1	13-533	FLUORESCENT FIXTURE, (NO TUBES)
2	13-534	24" FLUORESCENT TUBE
3	010216	PROTECTOR, LIGHT
4	24-054-64	WINDOW GASKET, 64" IN LENGTH
5	13-655	SWITCH
6	13-605	HEYCO CONNECTOR
7	13-550	POWER CORD, 3 WIRE
8	B198-2	SWITCH MOUNTING PLATE
9	010172F	CORD WITH FEMALE PLUG
10	010800 LBLTBX	COMPLETE LIGHT BOX (EXCEPT 3 & 4)

**Figure 4**



**LITTLE-BLASTER™**  
**BLAST GUN ASSEMBLY**

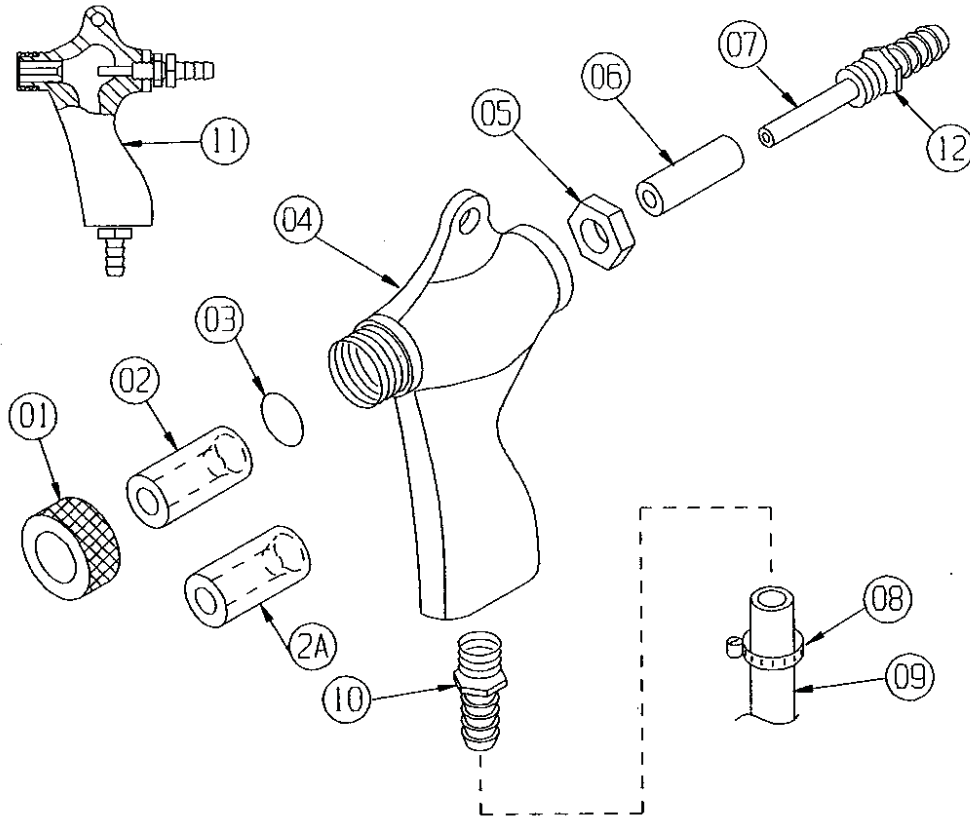

ITEM NO.	PART NO.	DESCRIPTION
1	20-054	NOZZLE NUT HOLDING
*2	20-074	NOZZLE CERAMIC, 1/4" I.D. SIZE 4
2	20-075	NOZZLE CERAMIC, 5/16" I.D. SIZE 5
2	20-076	NOZZLE CERAMIC, 3/8" I.D. SIZE 6
2A	20-084	NOZZLE CARBIDE, 1/4" I.D. SIZE 4
2A	20-085	NOZZLE CARBIDE, 5/16" I.D. SIZE 5
2A	20-086	NOZZLE CARBIDE, 3/8" I.D. SIZE 6
3	20-053	"O" RING - NOZZLE SEALING
4	20-040	GUN BODY ONLY
5	20-052	LOCKNUT, DRIFICE
6	20-063	RUBBER COVER, DRIFICE
*7	20-064	DRIFICE AIR 4/32" I.D. SIZE 4 INCLD. #6 & 7
7	20-065	DRIFICE AIR 5/32" I.D. SIZE 5 INCLD. #6 & 7
7	20-066	DRIFICE AIR 6/32" I.D. SIZE 6 INCLD. #6 & 7
8	21-032	CLAMP, HOSE
9	18-084	HOSE, MEDIA 1/2" I.D. (SPECIFY LENGTH)
10	14-302	FITTING-HOSE TO GUN 1/2" HOSE x 3/8" MPT
11	20-041	GUN, STD. COMP. W/CERAMIC NOZZLE (SPECIFY SIZE)
11	20-042	GUN, STD. COMP. W/CARBIDE NOZZLE (SPECIFY SIZE)
12	-----	GUN SIZE IS STAMPED ON AIR DRIFICE HEX
*13	20-041-4	STANDARD SUPPLIED WITH CABINET

**Figure 5**

**LITTLE-BLASTER™**  
**LB-300 CFM RECLAIMER**

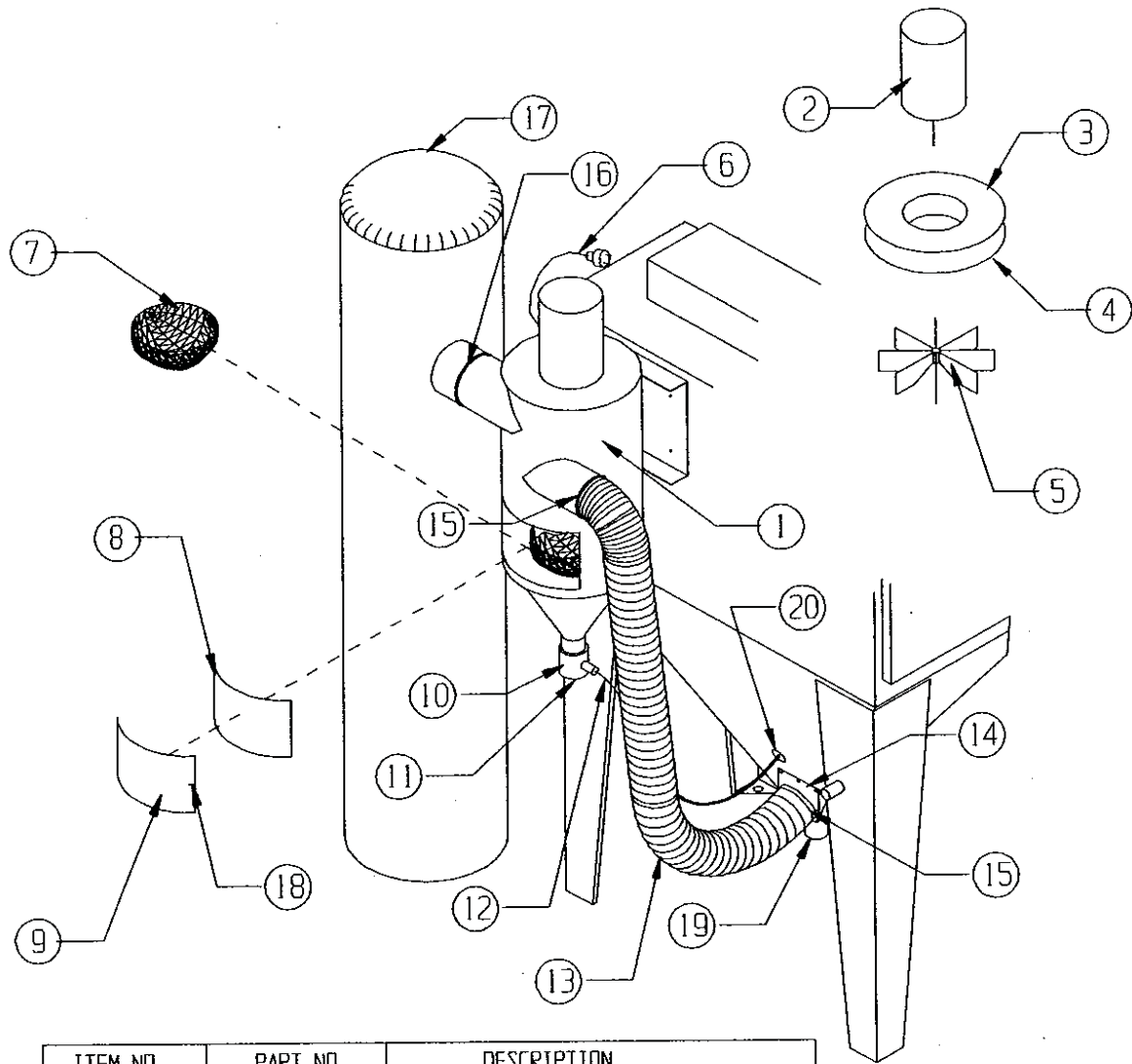

ITEM NO.	PART NO.	DESCRIPTION
1	009029	RECLAIMER HOUSING
2	13-400	MOTOR
3	11-426	MOTOR PLATE
4	24-030-3	MOTOR PLATE GASKET
5	11-418	BLADE ASSEMBLY
6	010172	ELECTRICAL CORD & PLUG
7	11-406	TRASH SCREEN BASKET
8	11-403	RECLAIM DOOR GASKET
9	11-402	RECLAIM DOOR
10	20-200	2" MEDIA VALVE
11	20-201	2" MEDIA VALVE PLUG
12	18-084	MEDIA HOSE
13	19-092-5	4" FLEX HOSE (5' SECTION)
14	A590	SLUMP FLEX HOSE ADAPTOR
15	21-034	FLEX HOSE CLAMPS
16	21-035	DUST BAG CLAMP
17	11-415	DUST BAG
18	15-728	RECLAIM DOOR LATCH
19	010217	2" PIPE CAP
20	24-050	GROMMET

**Figure 6**

# LITTLE-BLASTER™

## ELECTRICAL DIAGRAM

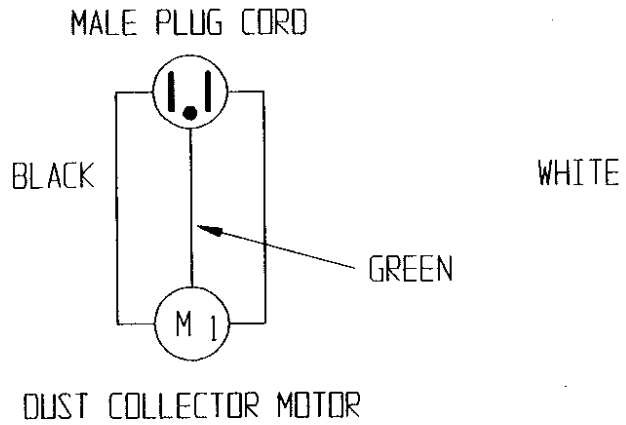
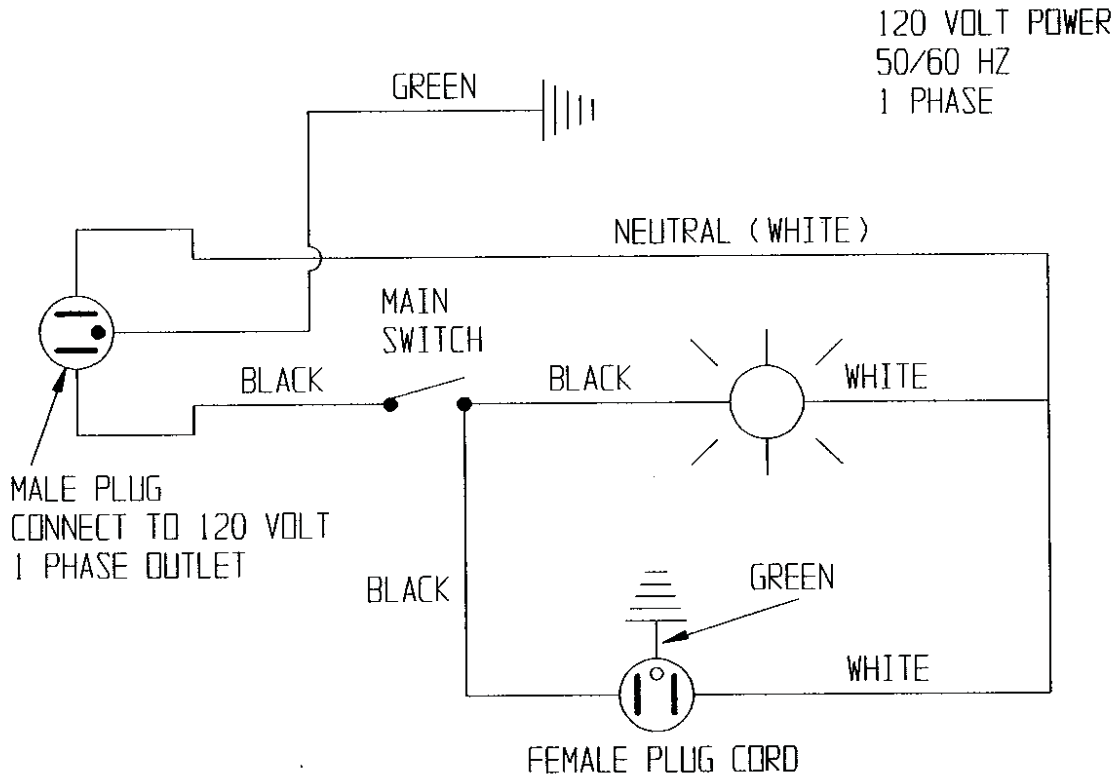

**Figure 7**

# LITTLE-BLASTER™

## SET-UP INSTRUCTIONS

### OYSTER SHELL MODELS

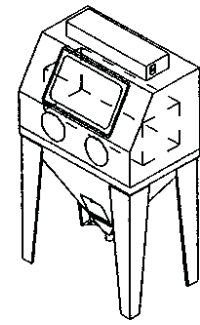
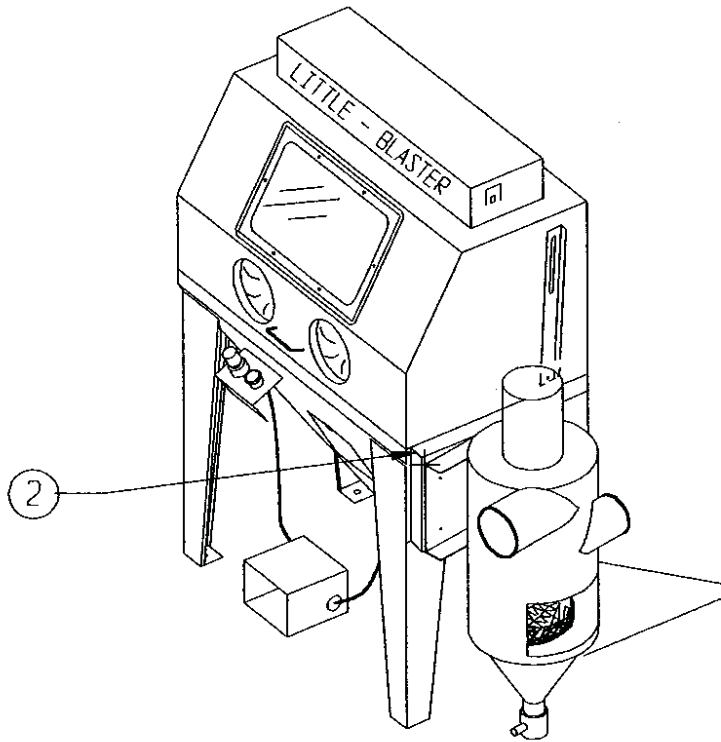

Fig. A

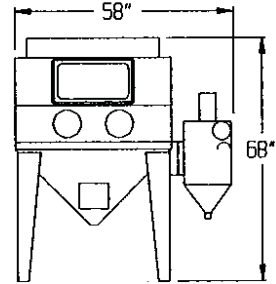

Fig. B

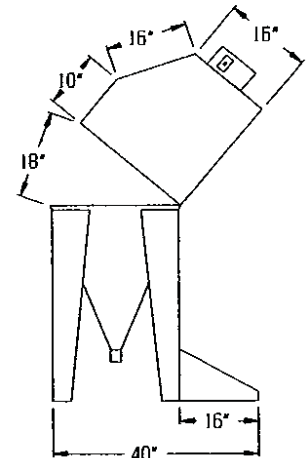

Fig. C

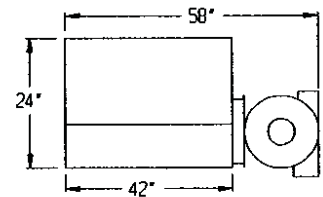
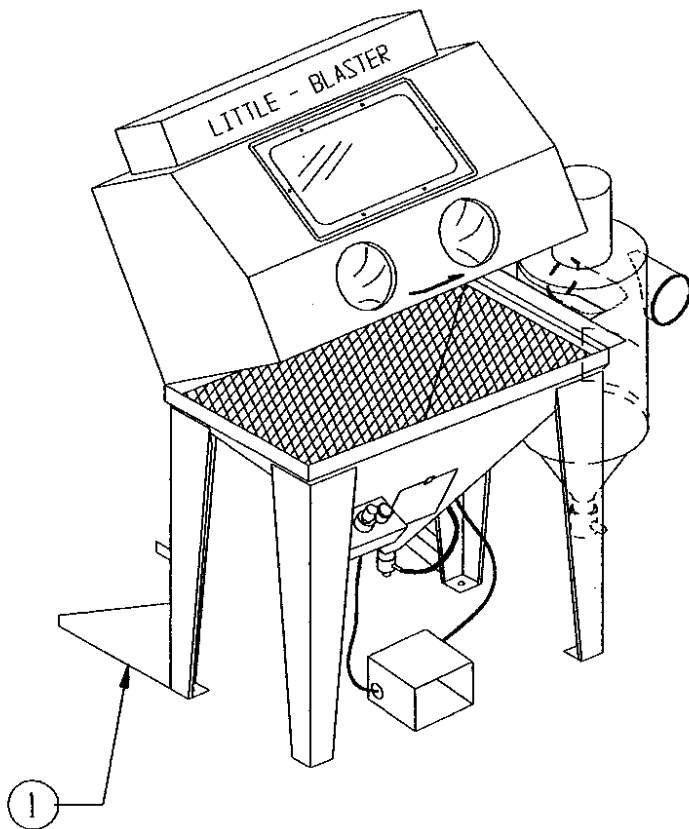

Fig. D

**Figure 8**

## WARRANTY

Larry Hess & Associates, Inc. Warrants to the original purchaser the merchandise sold to be free from defects in material and workmanship under normal use and service for a period of one (1) year. Upon prompt notification by the buyer, to LHA, components that are determined by LHA to be defective will be repaired or replaced at no additional charge, F.O.B. our factory.

Manufacturer shall have the right to inspect prior to replacing all merchandise in question.

This warranty does not apply to parts that are directly involved in the blasting operation. Example: gun, gun parts, viewing window, hose, gloves, etc.

Manufacturer shall not be required to pay any removal or installation charges whatsoever under this warranty.

Manufacturer shall not be liable for prospective profits, special or consequential damages, nor shall any recovery of any kind against manufacturer be greater in amount than the cost of repairs of defects in workmanship.

This warranty does not apply to damage caused by accidents, damage in transit, alterations by unauthorized personnel, abuse or damage by flood, fire, or acts of God, nor by artificially generated electric currents or any other cause whatsoever except defects in material or factory workmanship.

In all cases, defective parts must be returned to Larry Hess & Associates, Inc. before credit is issued.

If genuine BLAST-IT-ALL® replacement parts are not used, the warranty is void.

This warranty is in lieu of all other warranties expressed or implied and releases Larry Hess & Associates, Inc. of all other obligations and liabilities whatsoever. This warranty neither assumes nor authorizes any person to assume any obligation other than those specified by this warranty.

## WARNING

DO NOT USE **SAND** SAND WILL CAUSE SILICA DUST, WHICH IS THE CAUSE OF SILICOSIS DISEASE, A CONDITION OF MASSIVE FIBROSIS OF THE LUNGS. ***THIS STATEMENT INDICATES POTENTIAL PERSONNEL HAZARD. FAILURE TO COMPLY WITH THESE INSTRUCTIONS MAY RESULT IN PERSONAL INJURY.***

Distributed By:



2717 Tobey • Indianapolis, IN 46219  
(317) 545-0665 • FAX (317) 545-0670 • (800) 800-0665  
[www.idsblast.com](http://www.idsblast.com)